

Excellent Clamping

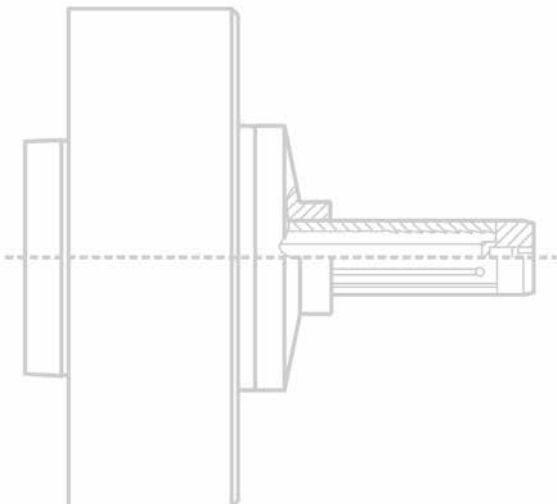

Mechanical Clamping Devices

Precise Mechanical Clamping Devices for All Requirements

Experience in clamping technology

For decades, König-mtm has been a leading manufacturer of state-of-the-art high-precision clamping devices.

The extensive production program covers clamping tools such as mandrels and chucks in hydraulic, mechanical or hydro-mechanical versions.

Clamping tools for market leaders

König-mtm's clamping chucks and the Königdorn® are well known in the tool industry and are well established as original equipment on top-class high-precision CNC controlled machine tools.

Mechanical clamping tools made by König-mtm

For today's machine tools the complexity of machining tasks, the variety of workpieces and subsequently, the number of clamping tools are increasing permanently.





Resulting from substantial experience in clamping technology König-mtm is developing tailor-made mechanical clamping tools, that cover a wide range of workpiece geometries by means of high loading clearances.

This high workpiece flexibility leads to reduced tooling expenses and higher productivity, meeting the basic requirement of more efficient machining operations.

We would be pleased to design and produce your tailor-made clamping tool, according to your specific requirements.

The following pages introduce some examples of clamping tools of our production. For a better representation of function we show graphical drawings.

Color code of clamping tool drawings

	Grey Königdorn®
	Blue/Light blue Königdorn® tooling (sectioned)
	Yellow Clamping areas of tooling
	Red Workpiece (partially sectioned)
	Green Base machine component

Advantages

- High loading clearances
- Reduced tooling set-up expense, high productivity (high workpiece flexibility)
- Short clamping lengths
- High workpiece tolerances possible
- Run-out accuracies up to 0,003 mm attainable
- High lateral rigidity due to flat-face contact of the workpiece
- High torque transmission
- Symmetrical expansion of clamping collet
- Quick change-over to other clamping diameters possible

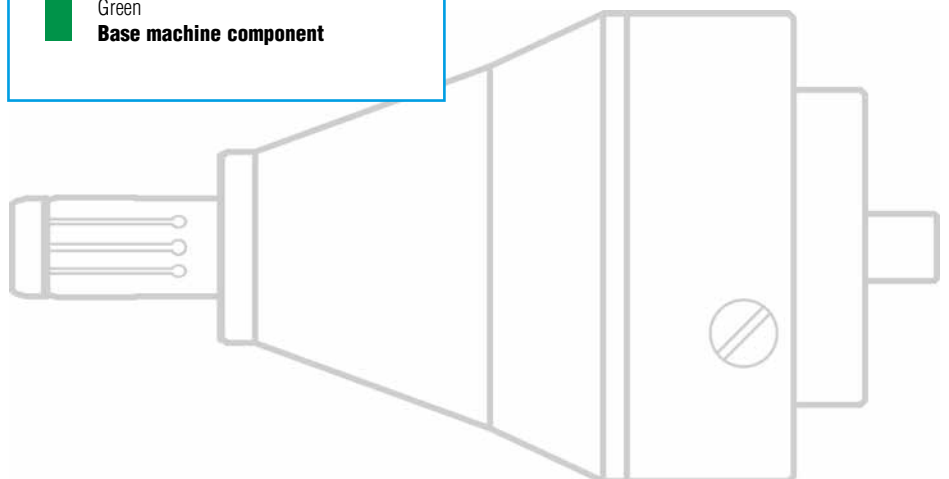

Mechanical Clamping Tools

Element Clamping Tools

Mechanical mandrels with fully segmented clamping bushings

Type E1 and E2

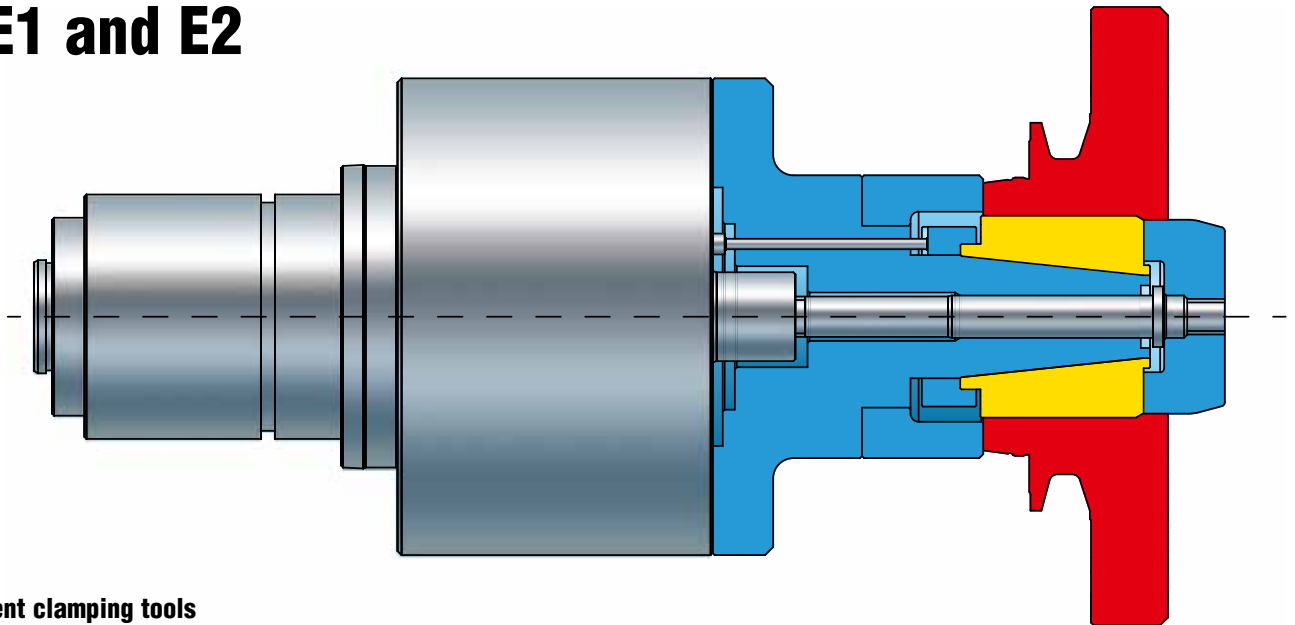

Special element clamping tools

To meet and exceed your requirements for higher work-piece tolerances and increased loading clearances, König-mtm has developed new mechanical mandrels with fully segmented collet elements.

The segmented clamping bushings consist of a combination of a high-quality tool steel and a high-tech elastomer.

These mechanically expanding clamping tools are ideally suited for medium and large clamping diameters and offer, depending on their size, expansion rates of 0.5 up to 1.3 mm. The actuation can be initiated by hydraulic pressure, pull rod or an internal spring package.

Each of these element clamping devices are tailor-made and precisely machined to your exact specifications and demands and can easily be adapted to almost every available high-precision machine tool. You benefit from the high precision, increased workpiece flexibility, and reduced lead time for a new device.



Type E1 segmented clamping bushings are especially suitable for large and medium clamping diameters e.g. for large workpieces with higher weight.



Type E2 segmented clamping bushings are suitable for compact workpieces with smaller diameters.

Mechanical Clamping Tools

Single-Taper Clamping Tools

Single-taper mandrel

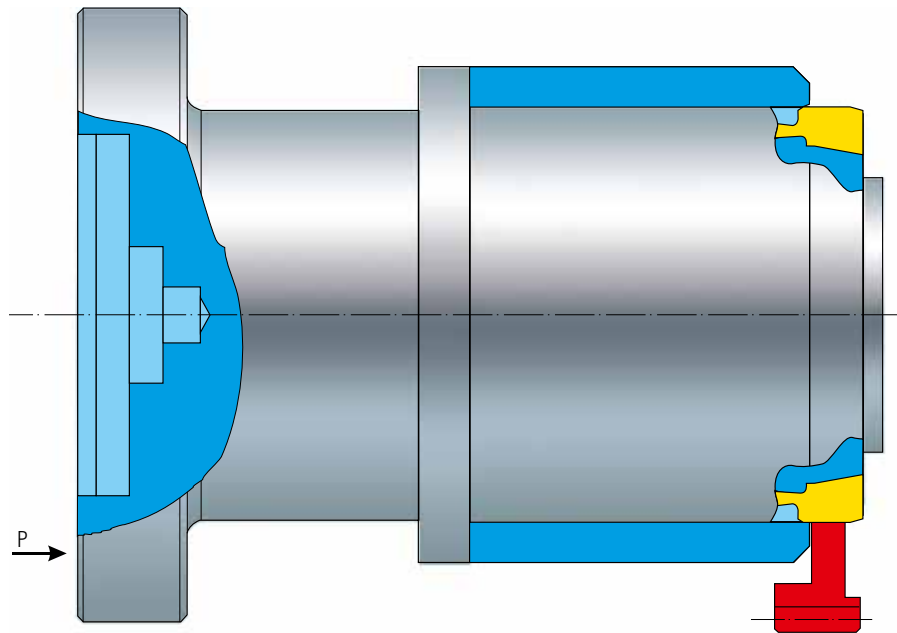

This solution is used for components with short clamping lengths and/or large diameters as well as for workpieces that require higher clearances for automatic loading.

The mandrel is directly mounted on the machine spindle and is actuated via the machine hydraulics. For clamping, a slotted collet will be expanded over the single taper. A secure process is guaranteed by additional holes for part present control.

Mechanical Clamping Tools

Single-Taper Clamping Tools

Single-taper mandrels

Clamping with single-taper and push rod

This mandrel is actuated by the push rod of the machine.

By means of integrated springs the Königdom® relaxes automatically.

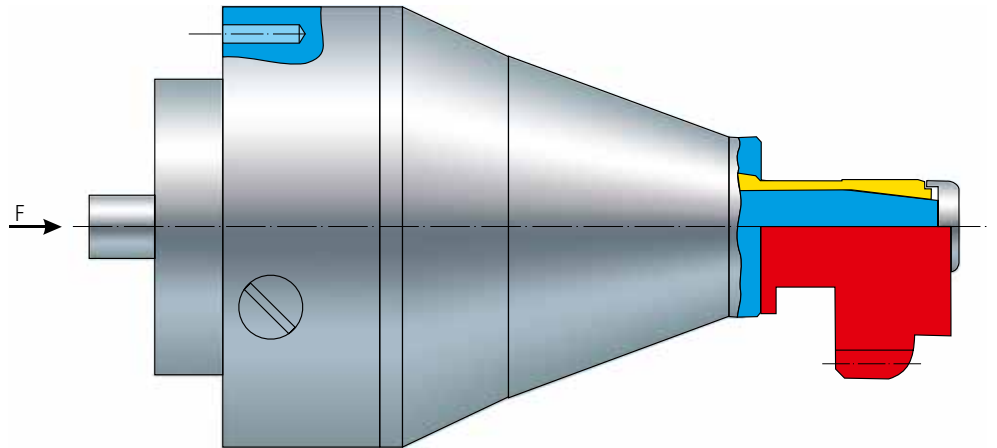

Clamping with single-taper and pull rod

Mechanical mandrel axially actuated by the pull rod of the machine.

- Changeable clamping sleeves ensure high flexibility
- Increases in torque transmission are achieved due to axial contact force

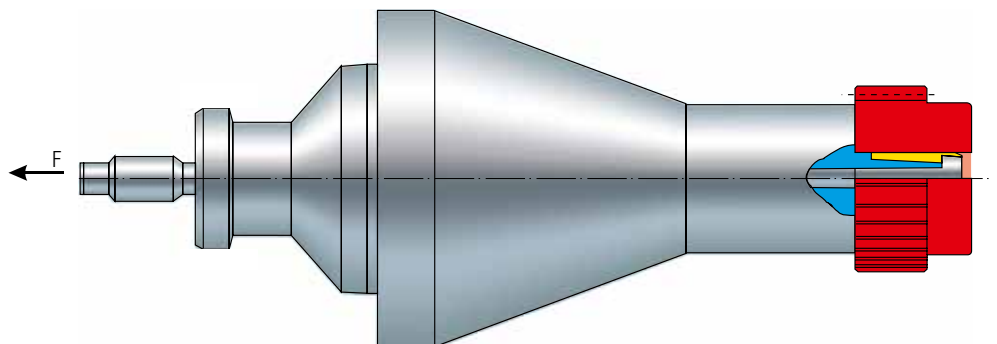

Mechanical Clamping Tools

Single-Taper Clamping Tools

Single-taper chuck

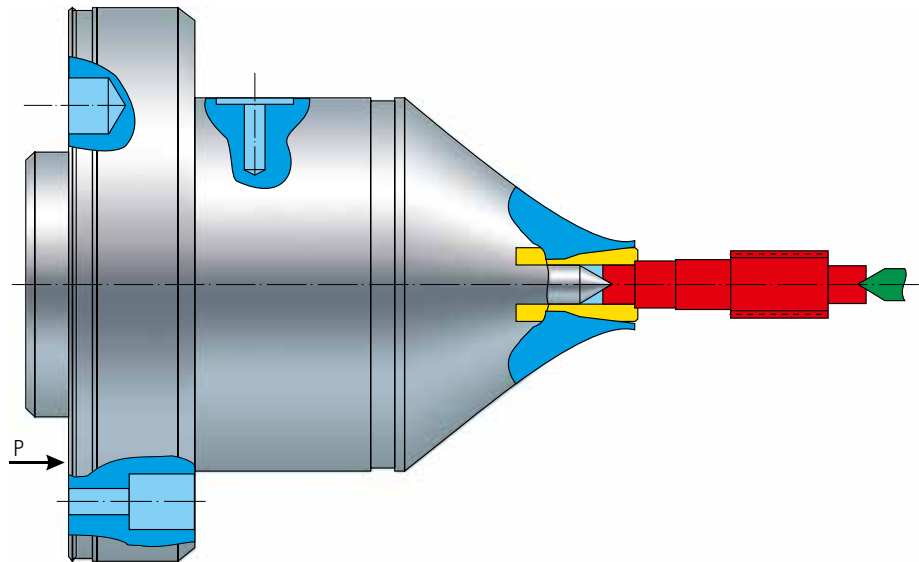

Example for a gear grinding application:
mechanical Königsdorn® chuck for machining
pinion shafts.

An internal center aligns the pinion shaft.
The clamping function occurs by means of a
tapered collet, activated by the machine
hydraulics.

The additional use of a machine tailstock
allows a perfect gear grinding operation.

The components are located between centers.
An integrated pressure spring package allows
a perfect relaxing of the chuck.

Friction taper chuck

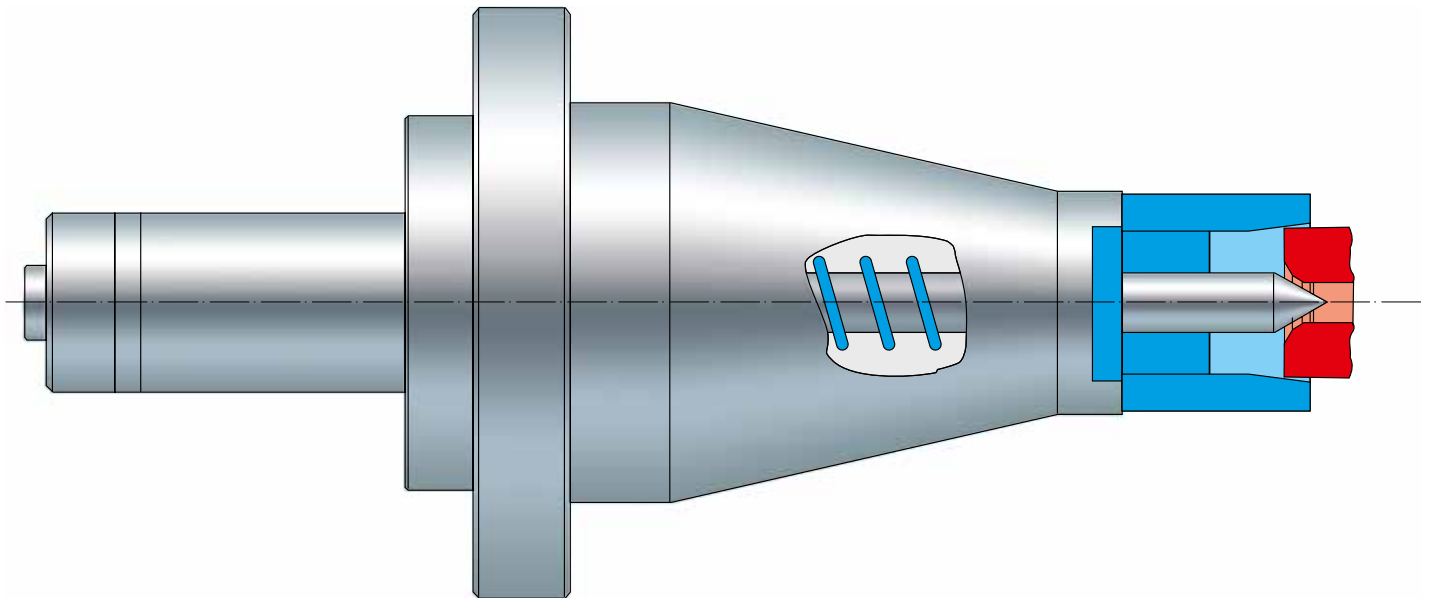

Chuck for applications with small shaft components and limited space for the clamping device

Quick and simple clamping is achieved by using a friction taper that provides sufficient torque transmission.

A live tailstock center is used to set the workpiece in the internal taper with sufficient force to achieve the required torque transmission capability.

- High run-out accuracy
- Workpiece ejector available on request

The Function Principle of Multi-Taper Clamping Tools

Multi-taper clamping tools are the best choice in case of greater tolerances and more loading clearance

In the automated process the demand for high loading clearance intends to cover a maximum part range without retooling.

The function principle of multi-taper tools allows higher loading clearances than conventional hydraulic expansion tools.

The clamping sleeve is mounted on the base body. Due to a special thread profile and axial force the clamping sleeve moves axially. The result is a fully cylindrical expansion which leads to workpiece clamping. Depending on the application and the clamping diameter, tolerances up to IT 13 can be obtained.

The cylindrical extension of a multi-taper clamping tool

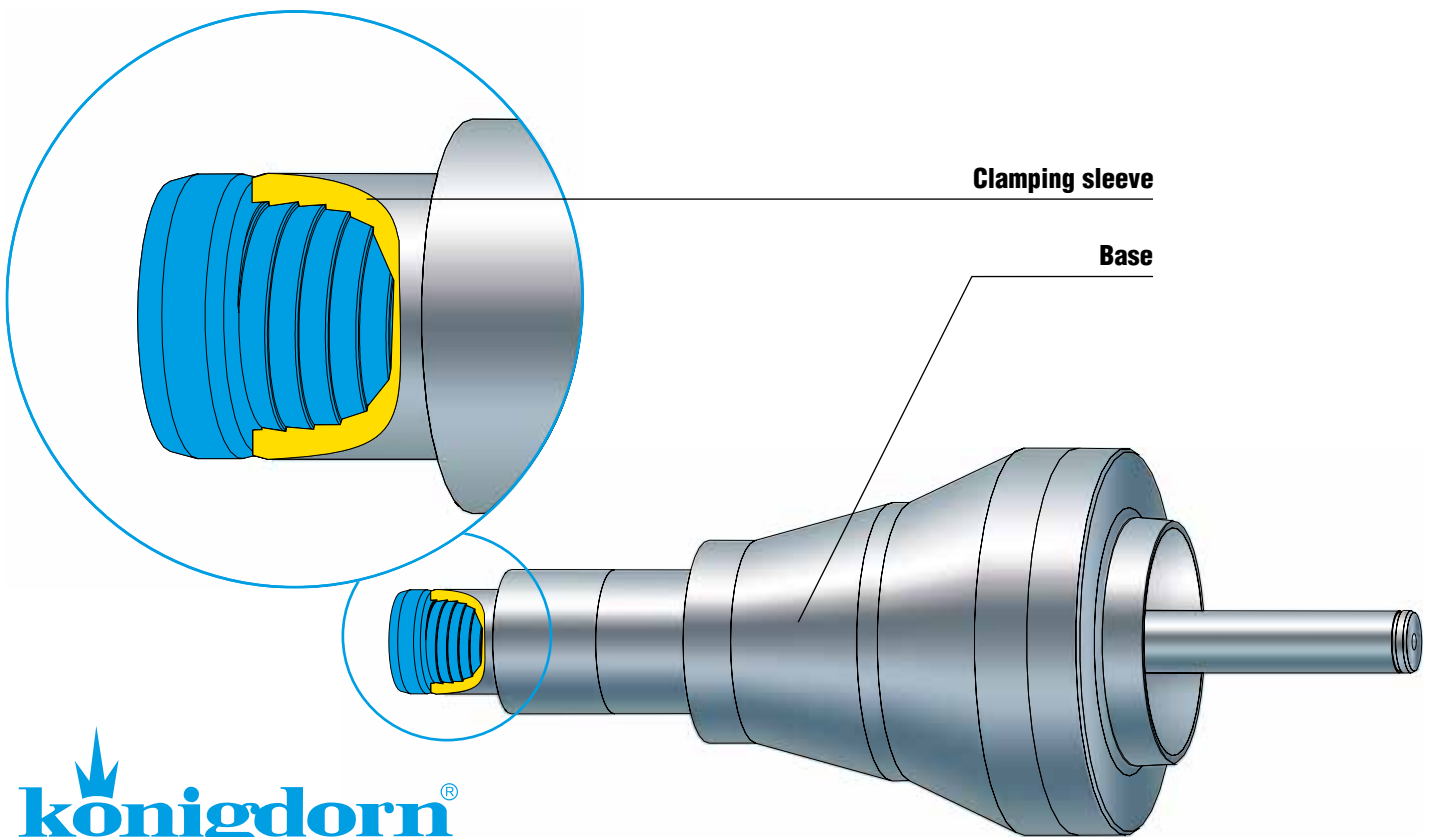
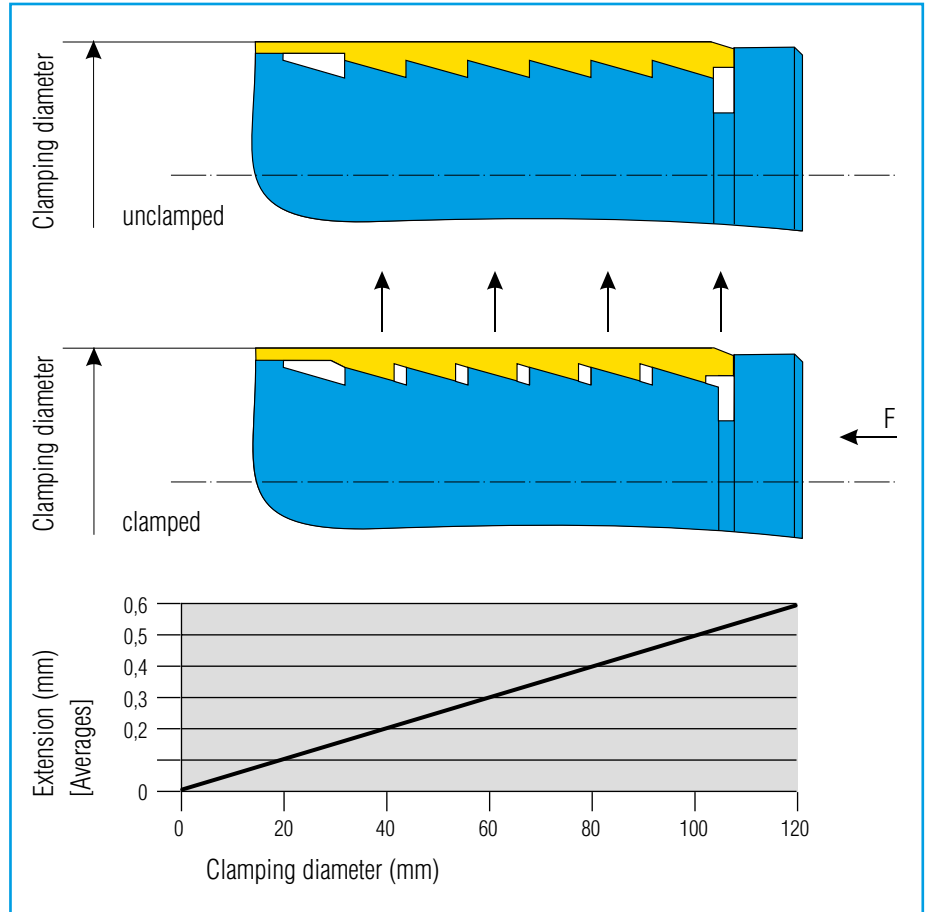

Mechanical Clamping Tools

Multi-Taper Clamping Tools

Multi-taper mandrel

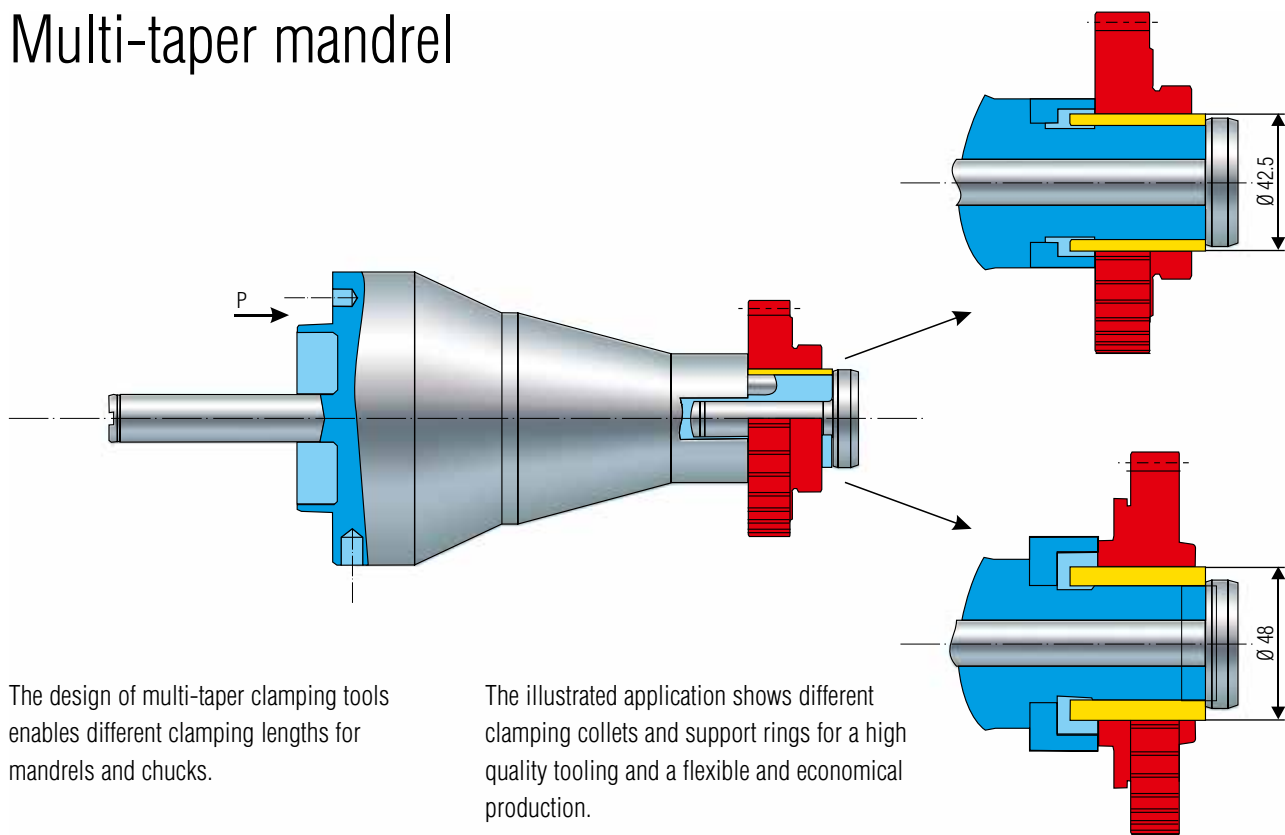

Multi-taper chuck

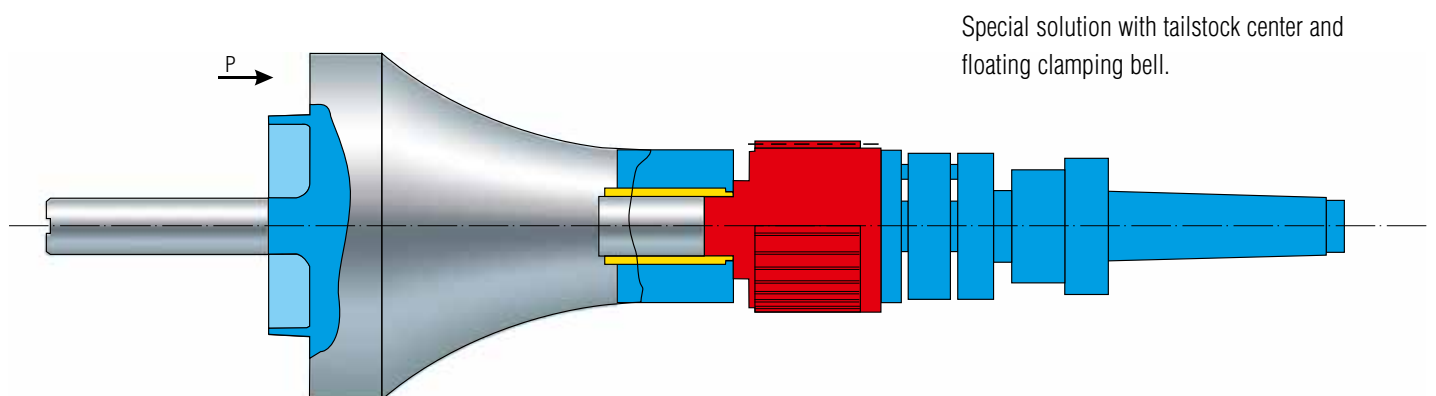

Mechanical Clamping Tools

Quick-Change Systems

Mechanical Quick-Change System

Quick and easy tool change

The mechanical quick-change clamping system of König-mtm provides an extremely fast and very easy change of the clamping device and a high degree of processing precision.

This results in a reduction of set-up efforts and set-up time as well as a prevention of possible assembly errors. Therefore, the efficiency of the production line can be significantly increased.

The integrated permanent clamping system enables secure clamping even in the event of a machine malfunction.

Special suitability for vertical hobbing machines

The mechanical quick-change clamping system was designed for the special use on vertical machine tools in connection with mechanical clamping devices made by König-mtm.

It can be used on all common hobbing machines due to the extremely flexible design. The machines need a pressure/pull rod with two functions.

- Ease of handling (no bolting-on)
- High workpiece flexibility
- Improved productivity
- High radial and axial run-out precision
- Robust construction
- High pull-down force
- Short tooling effort/time
- Especially suitable for mechanical clamping devices

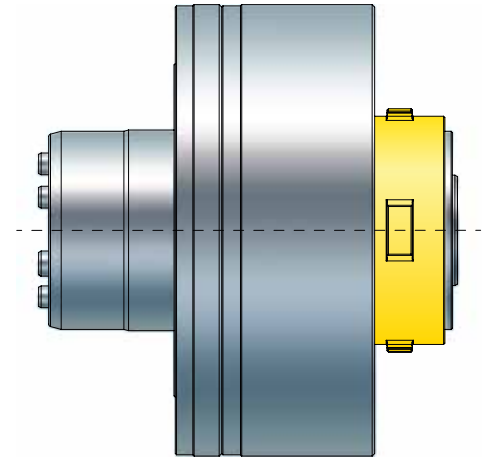

Mechanical Clamping Tools

Quick-Change Systems

Zero-point quick-change chucks

König-mtm is presenting clamping tools with zero-point quick-change system. High-precision quick-change chucks based on the zero-point pallet system are combined with Königdorn® clamping tools (hydraulic or mechanical mandrels or chucks).

Zero-point clamping systems facilitate extremely fast and simple tool change with maximum precision.

The newly developed, extremely sturdy and deflection-resistant joint between the clamping tool and pallet achieves outstanding repeat accuracy in both radial and axial run-out and is thus ideally suited for a wide range of machining processes, e.g. turning and hobbing through to high-precision gear grinding.

The zero-point quick-change chuck is permanent clamped (pneumatic unclamping automatically via machine tool or manually via blow gun).

The Königdorn® clamping tools are operated via the machine tool's hydraulics (by push-rod or oil pressure).

- Ease of handling (no bolting-on)
- High workpiece flexibility
- Improved productivity
- Maximum radial and axial run-out precision (repeat accuracy $\leq 3 \mu\text{m}$)
- Amenable to automation
- Minimal tooling effort/time
- Suitable for all clamping devices

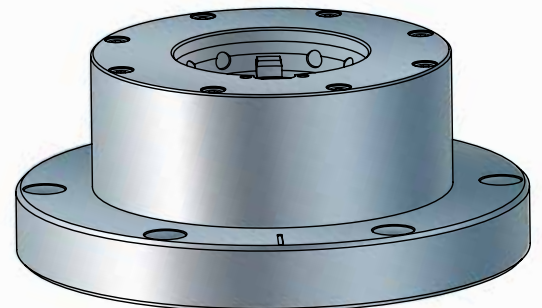
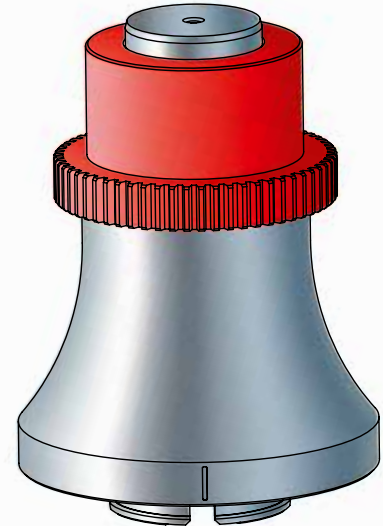



The König Group is located in Wertheim, the most northern town of Baden-Württemberg.

Lying on the confluence of the Main and Tauber rivers, the former seat court of the Count of Wertheim has a particular atmosphere with its ancient lanes, half-timbered houses and the castle ruins from the 12th century.

Production Program

- Mechanical mandrels
- Hydraulic mandrels
- Mechanical chucks
- Hydraulic chucks
- Splined mandrels
- Light-weight mandrels
- Complete holding devices
- Electronic clamping pressure control
- Special mandrels
- Clamping mandrels for hobs
- Rotor milling devices
- Special collet chucks
- Special flanges
- Spindles

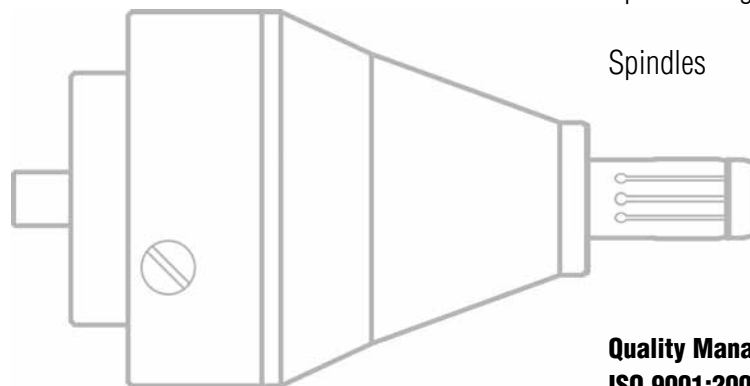

König-mtm GmbH, Spanntechnik

Postfach 14 63 · 97864 Wertheim
 Am Stammholz 13 · 97877 Wertheim
 Tel.: +49 (0) 93 42 8 76-0
 Fax: +49 (0) 93 42 8 76-1 23
 e-Mail: sales@koenig-mtm.de
 www.koenig-mtm.de

Quality Management:
ISO 9001:2008 certified

Environment Management:
ISO 14001 certified

© 2014 by König-mtm, Spanntechnik

Products and methods are subject to change without notice.